

P926 One 26W or 32W Triple Tube Lamp
P927 One 42W Triple Tube Lamp

Medium Beam
5 7/8" Conoid Apertures

Optics and Applications

Distribution from a single vertically mounted triple tube lamp is for general lighting. Spacing to mounting height ratios range from .93 to 1.11 depending upon which lamp is mounted. Use in corridors, entries, work stations or open area lighting in low to medium height ceilings.

Design Features

The two reflector optical system is protected by a rigid steel housing which keeps the reflectors in proper relationship to each other. The twist and lock socket prevents the lamp from falling if it is not properly engaged. It is a dependable fail-safe mechanism to prevent injury and litigation. Maximum ceiling thickness is 2". Ballast and lamp service from below.

Finish

Specular clear Alzak cones are standard. Optional colors and Softglow® finishes are available. Housings and structural parts are painted optical matte black to suppress stray light leaks. Steel parts are phosphate conditioned for corrosion resistance before painting.

Ballasts

Fully electronic, microprocessor controlled with variable starting current for inrush protection to assure rated lamp life. Input voltage ranges from 120V through 277V. Power factor .98, starting temperature 0° F (-18° C), THD < 10%. Pre-heat start < 1.0 second. End of lamp life protection. Rated for > 50,000 starts.

General

Fixtures are pre-wired, UL and C-UL listed for eight wire 75°C branch circuit wiring. Union made IBEW. Luminaire Efficiency Rating (LER) data is in the photometric directory located in Section Z.

Accessories

- G Gold cone.
- H Mocha cone.
- P Graphite cone.
- T Titanium cone.
- W Wheat cone.
- Y Pewter cone.
- Z Bronze cone.
- S Softglow® finishes: add S before color letters. e.g. SW for Softglow® wheat cone, SC for Softglow® clear cone.
- R2 26" support rails.
- R5 52" support rails.
- WT White trim flange.
- WHT White complete trim.
- V347 347 volt ballast.
- F Fuse.
- DM Dimming ballast. Specify watts and volts.
- EM Emergency power includes integral charger light and test switch visible through aperture. Single lamp operation for 90 minutes. Specify volts.
- WRL Wattage restriction label, specify wattage.

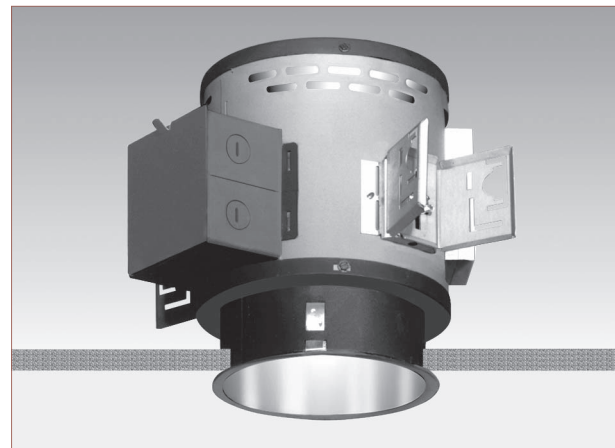

Dimensions and Lamps

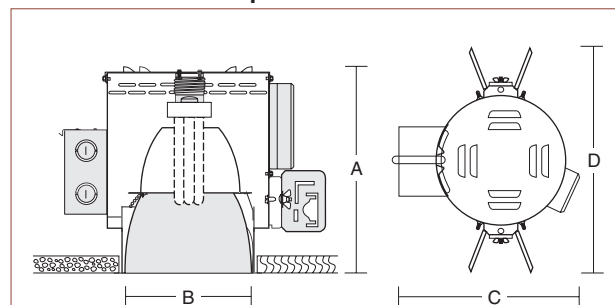

Number	A Depth*	B Aperture	C Width	D Length	Lamps
P926	9 3/4" 248mm	5 7/8" 149mm	10 1/2" 267mm	13 1/4" 337mm	26W or 32W Triple Tube
P927	10 1/4" 260mm	5 7/8" 149mm	10 1/2" 267mm	13 1/4" 337mm	42W Triple Tube

*Recess depth increases to 12 1/2" with EM and DM accessories.

Matching Units

Medium wide beam Page P52
 Wall washers Pages P61, P62, P63

P51 P926 P927

Performance Datachart

Single Unit Initial Footcandles, 30" Work Plane							Ceiling to Floor		Multiple Units Initial Footcandles, 30" Work Plane			
P926 One 32W Osram Triple Tube Read Top Data									Ceiling 80% Walls 50% Floor 20%			
P927 One 42W Osram Triple Tube Read Bottom Data									Spacing is Maximum Over Work Plane			
Nadir	10°		20°		30°				Spacing			
FC	FC	Diam	FC	Diam	FC	Diam			RCR 1	RCR 3	RCR 8	
37	35	2'	25	4'	13	6'	8'		5'	49	42	30
47	42	2'	30	4'	17	6'			5'	66	56	39
27	25	2'	18	5'	10	8'	9'		6'	35	30	21
33	30	2'	21	5'	12	8'			6'	47	40	28
20	19	3'	14	5'	7	9'	10'		7'	26	23	16
25	23	3'	16	5'	9	9'			7'	36	30	21
13	12	3'	8	7'	4	11'	12'		9'	17	14	10
16	14	3'	10	7'	6	11'			9'	22	19	13
9	8	4'	6	8'	3	13'	14'		11'	11	10	7
11	10	4'	7	8'	4	13'			11'	15	13	9

See notes 4, 5 and 6.

Candlepower Distribution

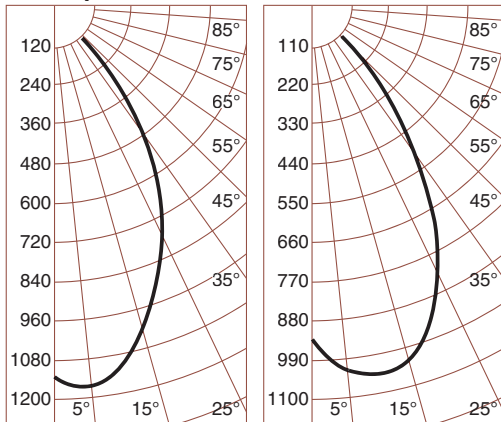

P926 32W Triple Tube Osram
Eff. 50% S/M .95

P926 32W Triple Tube Philips
Eff. 50% S/M 1.11

Candelas

o	O 32W	P 32W
	2400*	2400*
0	1134	938
5	1152	1021
10	1109	1055
15	1023	1020
20	916	956
25	789	837
30	625	667
35	460	467
40	353	321
45	212	173
50	19	16
55	7	6
60	0	0
65	0	0
70	0	0
75	0	0
80	0	0
85	0	0
90	0	0

o Vertical Angles
* Initial Lamp Lumens

Coefficients of Utilization

Ceiling	80%				70%				50%				30%				0
	70	50	30	10	50	10	50	10	50	10	50	10	50	10	0		
Wall %	Zonal Cavity Method - Floor Reflectance 20%																
RCR	Zonal Cavity Method - Floor Reflectance 20%																
1	.57	.56	.55	.53	.55	.52	.53	.51	.51	.49	.47						
2	.54	.52	.50	.48	.51	.47	.49	.46	.48	.45	.43						
3	.51	.48	.45	.43	.47	.43	.46	.42	.45	.41	.40						
4	.48	.44	.41	.39	.44	.39	.43	.38	.42	.38	.37						
5	.46	.41	.38	.36	.41	.36	.40	.35	.39	.35	.34						
6	.43	.38	.35	.33	.38	.33	.37	.33	.36	.32	.31						
7	.41	.36	.33	.30	.35	.30	.35	.30	.34	.30	.29						
8	.39	.34	.30	.28	.33	.28	.33	.28	.32	.28	.27						
9	.37	.31	.28	.26	.31	.26	.31	.26	.30	.26	.25						
10	.35	.30	.26	.24	.29	.24	.29	.24	.28	.24	.23						

P926 One 32W Triple Tube Osram Sylvania
P926 One 32W Triple Tube Philips x .98

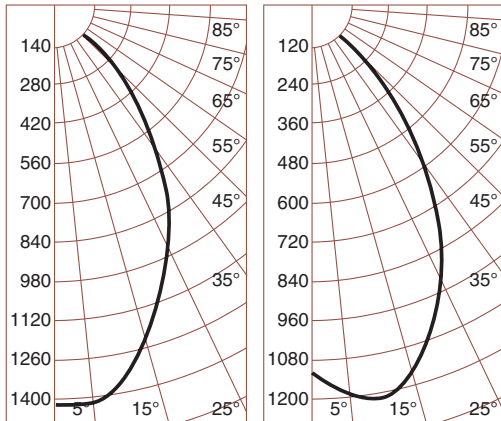

P927 42W Triple Tube Osram
Eff. 48% S/M .93

P927 42W Triple Tube Philips
Eff. 44% S/M 1.07

o	O 42W	P 42W
	3200*	3200*
0	1412	1104
5	1403	1188
10	1328	1211
15	1176	1154
20	1092	1063
25	958	919
30	789	747
35	611	583
40	487	441
45	355	253
50	75	23
55	10	8
60	0	0
65	0	0
70	0	0
75	0	0
80	0	0
85	0	0
90	0	0

o Vertical Angles
* Initial Lamp Lumens

Ceiling	80%				70%				50%				30%				0
	70	50	30	10	50	10	50	10	50	10	50	10	50	10	0		
Wall %	Zonal Cavity Method - Floor Reflectance 20%																
RCR	Zonal Cavity Method - Floor Reflectance 20%																
1	.56	.55	.54	.53	.54	.52	.52	.50	.50	.49	.46						
2	.53	.51	.49	.47	.50	.47	.48	.46	.47	.45	.43						
3	.51	.47	.45	.43	.47	.42	.45	.42	.44	.41	.39						
4	.48	.44	.41	.39	.43	.38	.42	.38	.41	.38	.36						
5	.45	.41	.38	.35	.40	.35	.39	.35	.39	.35	.34						
6	.43	.38	.35	.33	.38	.32	.37	.32	.36	.32	.31						
7	.40	.35	.32	.30	.35	.30	.34	.30	.34	.30	.29						
8	.38	.33	.30	.28	.33	.28	.32	.28	.32	.27	.27						
9	.36	.31	.28	.26	.31	.26	.30	.26	.30	.26	.25						
10	.34	.29	.26	.24	.29	.24	.29	.24	.28	.24	.23						

P927 One 42W Triple Tube Osram Sylvania
P927 One 42W Triple Tube Philips x .89

Brightness

Number	Lamps	85°	75°	65°	55°	45°
P926	32W Osram Sylvania Triple Tube	10	33	66	150	12837
	32W Philips Triple Tube	12	34	62	151	10756
P927	42W Osram Sylvania Triple Tube	14	45	91	208	17796
	42W Philips Triple Tube	15	45	82	203	14468

Data in footlamberts. Photometer readings, Maximum Brightness Method. See note 7.

Notes

- Data on all charts calculated with a clear specular cone finish.
- Specular cone multipliers: Wheat x .84, Pewter x .79, Mocha x .78, Graphite x .75, Titanium x .75, Bronze x .72.
- Softglow® cone multipliers: Wheat x .71, Mocha x .68, Pewter x .65, Graphite x .64, Titanium x .64, Bronze x .61.
- Single unit Datachart pattern diameters are determined by the number of degrees from each side of nadir. Therefore a 20° diameter represents a total 40° pattern width at the work plane 30" above the floor. Footcandle values are at the edge of that diameter.
- Datachart spacing is rounded off to the nearest foot.
- Data by IES methods. Compact fluorescent data vary due to lamp differences, power input, burning position, ambient temperature and ballast characteristics. Apply a modification factor.
- Brightness data from the Average Luminance Method are inaccurate for small aperture downlights. They are theoretical calculations derived for large surfaces such as troffers. For a complete discussion refer to section Z brochure Z1.